

83 DN40-DN50



EN Description

The pressure independent control valve (PICV) combines the functions of a differential pressure controller, regulation valve and 2 port control valve into a single body.

The EVOPICV incorporates a small diaphragm type DPCV in order to keep a constant differential pressure across an orifice and to provide a constant flow rate whilst the differential pressure is within the operating limits of the valve. Beyond these working pressures the valve acts as a fixed orifice.

Making this orifice adjustable allows the valve to be pre-set to deliver a range of flow rates. In the case of the EVOPICV valve this adjustment can be made in situ without removing any covers or actuators if the accessory **081PR1** is on; this device is already mounted on the valves. The adjustment wheel is lockable.

The EvoPICV valve also includes 2 port temperature control by means of an special pattern ball valve. The hole of the ball valve is machined to give a near equi-percentage flow control characteristic. Due to the fact that the differential pressure across the valve seat is constant it can be said that the authority of this control valve is very close to 1.

Due to the way the EVOPICV valve controls the flow rate, irrespective of differential pressure branch and sub mains, balancing valves are not required. The flow rate is maintained at the terminal unit regardless of system conditions making the valve ideal for systems with inverter driven pumps.

By turning 180° the ball the valve becomes a fullport valve and the pressure regulator get blocked. So the flashing of the valve is possible.

EN Valve features

The 83 series PICV valve offers the following functions:

- Good valve authority to maintain temperature control and power output from the terminal unit using the complete stroke of the valve.
- Maximum design flow limitation: once set, the 83 valve maintains design flow regardless of pressure changes in the system.
- it can easily be set up once installed, using the actuator or by means of the device **081PR1**.
- Measure by means of specific meter of the differential pressure across the valve: in this way user can verify if the start-up pressure has been reached and overpassed.

ΔP max.	Close off pressure	Temperature	Working pressure max.	Stroke	Rangeability	Leakage	Accuracy 0 ÷ 1 bar*
600 kPa / 6 bar	600 kPa / 6 bar	-10 ÷ 120 °C	1600 kPa / 16 bar	90°	>100 IEC 60534-2-3	Class IV IEC 60534-4	± 5%

	83HPR1 1 1/4"	83LPR1 1 1/2"	83HPR1 1 1/2"	83VLPR1 2"	83LPR1 2"	83HPR1 2"
Flow rate max.	6000 l/h 1,67 l/s	6000 l/h 1,67 l/s	9000 l/h 2,5 l/s	11000 l/h 3,06 l/s	12000 l/h 3,33 l/s	18000 l/h 5,00 l/s
Start-up max.	30 kPa 0,30 bar	30 kPa 0,30 bar	35 kPa 0,35 bar	40 kPa 0,40 bar	35 kPa 0,35 bar	35 kPa 0,35 bar
Connections	Rc 1 1/4" union F EN 10226-1	Rc 1 1/2" union F EN 10226-1	Rc 1 1/2" union F EN 10226-1	Rc 2" union F EN 10226-1	Rc 2" union F EN 10226-1	Rc 2" union F EN 10226-1

* at 100%. For other presetting and differential pressure, refer to "Flow setting accuracy" on the PICV manual.



EN Dimensional data

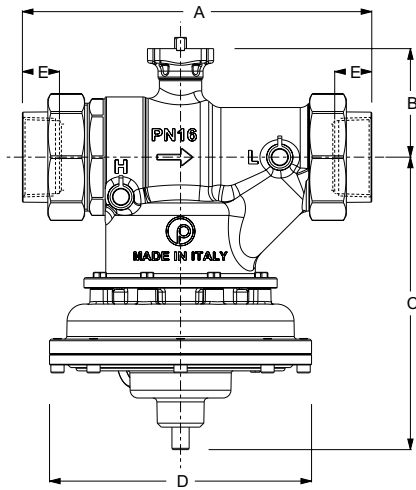

Manual valve with presetting 081PR1 mounted							
Art.	DN	Flow rate [l/h]	A (mm)	B (mm)	C (mm)	D (mm)	E (mm)
83HPR1 1 1/4"	40	6000	232	89	176	158	23,6
83LPR1 1 1/2"	40	6000	231	89	176	158	23,6
83HPR1 1 1/2"	40	9000	231	89	176	158	23,6
83VLPR1 2"	40	11000	278	89	176	158	23,6
83LPR1 2"	50	12000	267	97	221	198	28
83HPR1 2"	50	18000	267	97	221	198	28

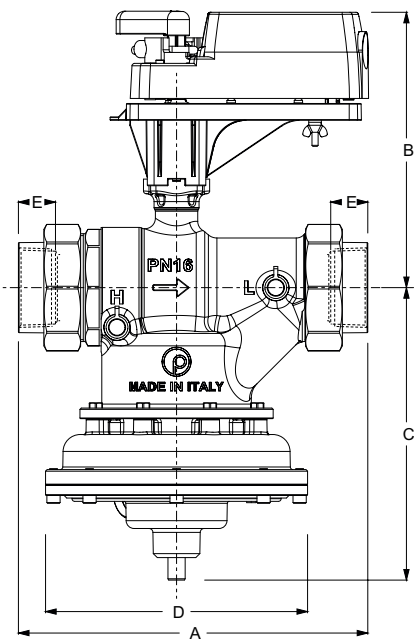
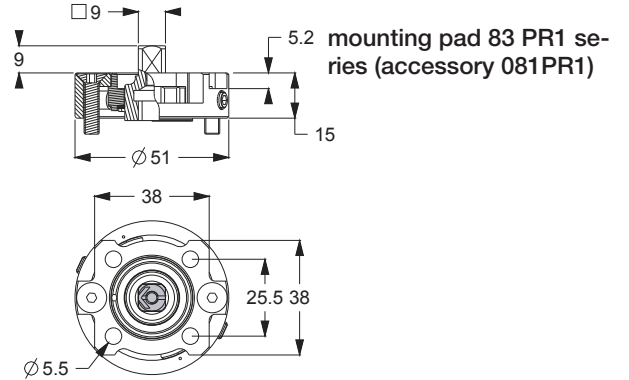

Rotary actuator serie SN08 with presetting 081PR1 mounted							
Art.	DN	Flow rate [l/h]	A (mm)	B (mm)	C (mm)	D (mm)	E (mm)
83HPR1 1 1/4"	40	6000	232	221	176	158	23,6
83LPR1 1 1/2"	40	6000	231	221	176	158	23,6
83HPR1 1 1/2"	40	9000	231	221	176	158	23,6
83VLPR1 2"	40	11000	278	221	176	158	23,6
83LPR1 2"	50	12000	267	229	221	198	28
83HPR1 2"	50	18000	267	229	221	198	28

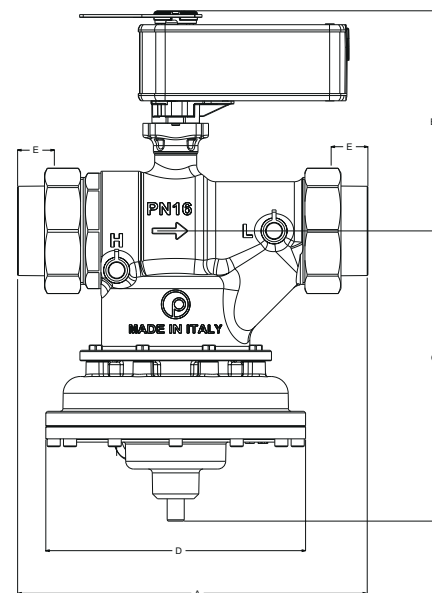

Rotary actuator serie VA9208 - VA9208C with presetting 081PR1 mounted							
Art.	DN	Flow rate [l/h]	A (mm)	B (mm)	C (mm)	D (mm)	E (mm)
83HPR1 1 1/4"	40	6000	232	174	176	158	23,6
83LPR1 1 1/2"	40	6000	231	174	176	158	23,6
83HPR1 1 1/2"	40	9000	231	174	176	158	23,6
83VLPR1 2"	40	11000	278	174	176	158	23,6
83LPR1 2"	50	12000	267	182	221	198	28
83HPR1 2"	50	18000	267	182	221	198	28

EN Materials and weight

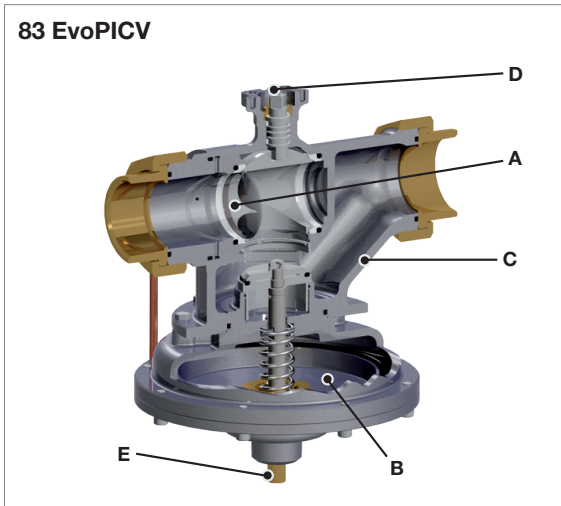

	Material list
Regulating valve (A)	Brass CW617N PTFE
Diaphragm (B)	Brass CW614N - EPDM-X Stainless steel AISI 303
Presetting (D) [PR1 series]	Brass CW617N
Body (C)	Ductile Iron
Gaskets	EPDM-x
Additional manual shut-off device (E)	Brass CW614N

Art.	Weight (kg)
83HPR1 1 1/4"	8,46
83LPR1 1 1/2"	8,46
83HPR1 1 1/2"	8,46
83VLPR1 2"	9,16
83LPR1 2"	15,66
83HPR1 2"	15,66

EN Installation and maintenance EvoPICV 83

1. Use conditions

The valve has to be mounted with the arrow in the direction of the flow. Mounting it in the wrong direction may damage the system and the valve itself. If flow reversal is possible, a non-return valve should be mounted. Minimum differential pressure above which the valve begins to exercise its regulating effect:

	83HPR1 1 1/4"	83LPR1 1 1/2"	83HPR1 1 1/2"	83VLPR1 2"	83LPR1 2"	83HPR1 2"
ΔP Start-up	30 kPa 0,30 bar	30 kPa 0,30 bar	35 kPa 0,35 bar	40 kPa 0,40 bar	35 kPa 0,35 bar	35 kPa 0,35 bar

Medium
Water / Water+glycol 30%



2. Flow preset

The presetting device limits the ball stroke. To set the selected flow, follow these steps:

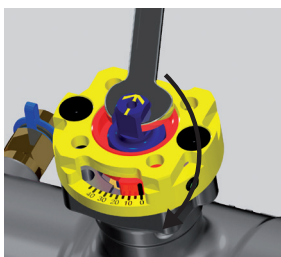

Close the valve

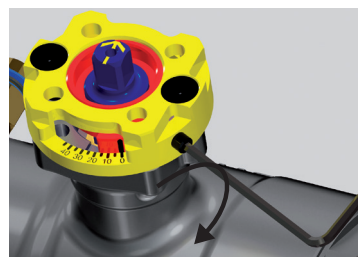

Release locking device

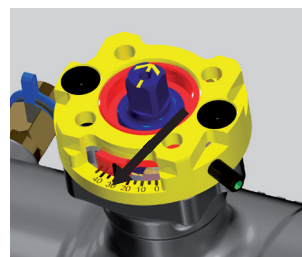

Set maximum flow rate

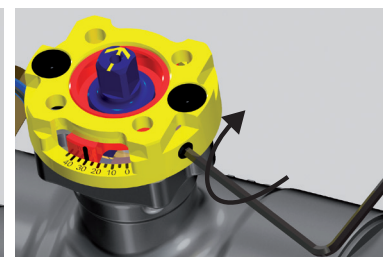

Lock again and re-open the valve. Don't overtighten. Could seriously damage the device. Torque 2÷3 Nm



3. Operating control

It is necessary to be sure that the valve is actually working in the operating range. In order to verify it, just measure the differential pressure across the valve, as shown in the picture.

If the measured differential pressure is higher than the start-up pressure, the valve is actually keeping the flow constant at the set value.

Pettinaroli MDPS2 is the device which allows to do it: along with a smartphone and the dedicated app, it can directly give the user the differential pressure compared to the start-up differential pressure of the valve (proper valve has to be selected among all the Pettinaroli EvoPICV catalogue).

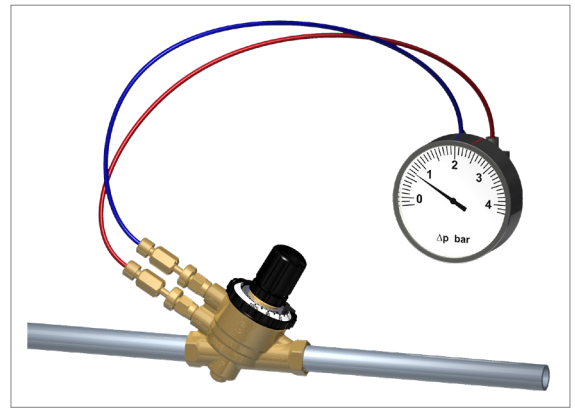

4. Maintenance and cleaning

During valve cleaning operations, use a damp cloth. DO NOT use any detergent or chemical product that may seriously damage or compromise the proper functioning and the reliability of the valve.

5. Flushing and shut off

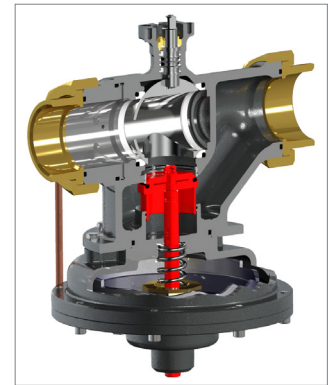
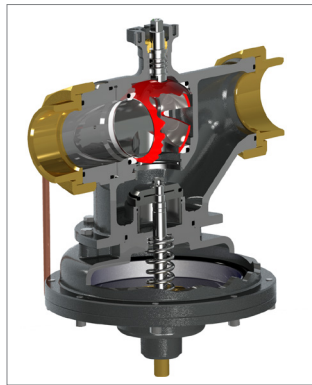
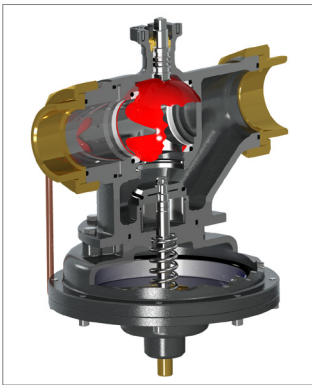

Flushing can be made through the valve by turning the valve 180°. The differential pressure reducer is now inhibited and no flow limitation occurs.

Remember to restore the valve in its working position after flushing.

The valve can be closed through the cartridge, should there be the need to do so, by using a 6 mm allen key.

In normal working conditions this shut off device must be fully open.

6. Actuator assembly

The valve can be equipped with electro-mechanical actuators, according to the requirements of the system. The mounting pad is made according to ISO 9210 F04 which accommodates selectable actuators.

For proper installation, always close the valve. The actuator must be in closed position too before assembling.

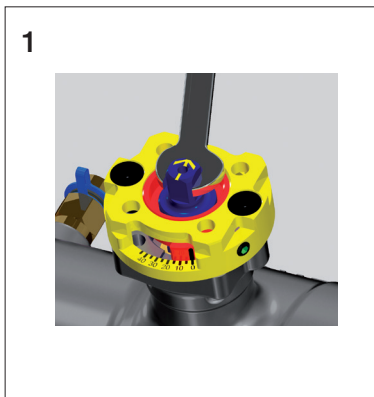

Close the valve and do the presetting. Do not open up the valve after the presetting. To close the valve, rotate the stem 90° clockwise (the arrow on the stem must be pointed towards the PT ports).

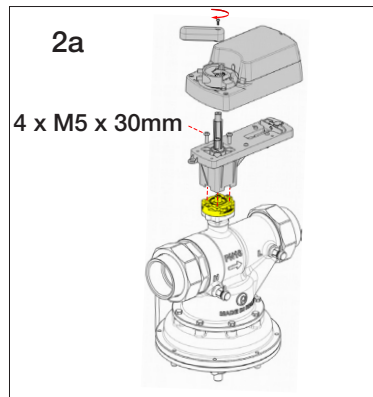

SN08 series assembling:

- put the stem adaptor, aligning the arrows;
- put and fix the support through the screws
- place and hold the actuator on the front (stem) and on the rear



VA9208 series assembling:

- place the actuator on the valve
- tighten the screw on the top of the actuator connection

EN Start-up curves and presetting

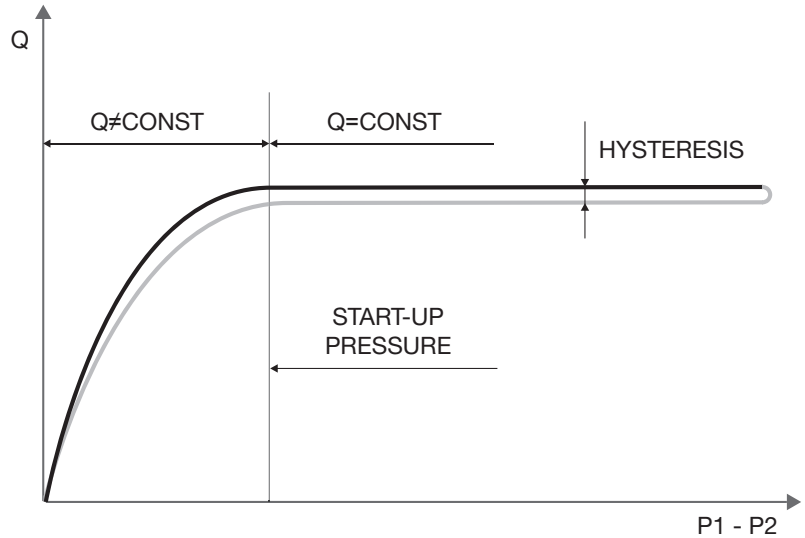
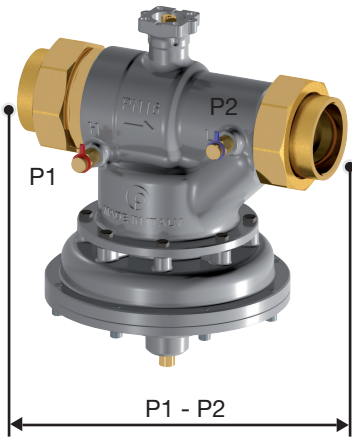

The example above shows a characteristic curve where start-up pressure, hysteresis and accuracy can be evaluated.

Using a differential pressure gauge to measure the pressure drop the valve absorbs, allows to check whether the valve is in the operating range (and, therefore, whether the flow is constant) by simply verifying that the measured value $P1 - P2$ is higher than the start-up value.

If the ΔP measured value is lower than the start-up value, then the valve works as a fixed orifice valve. Start-up value varies with flow setting of the valve, as shown by the example below:

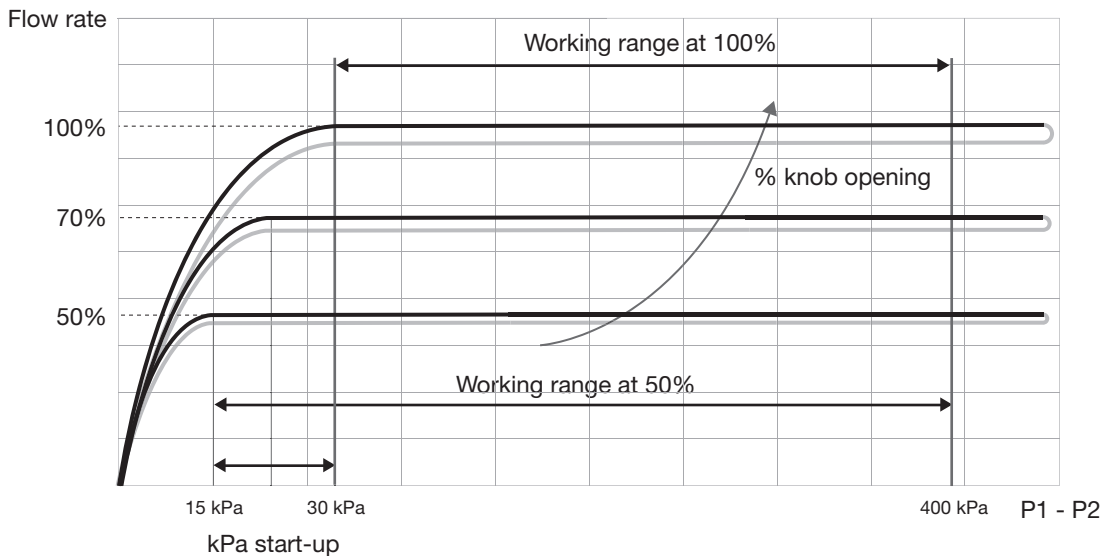

When the valve is set at 100% of nominal (maximum) flow, the curve begins to remain constant at 30 kPa, therefore the working range of the valve is $30 \div 400$ kPa;

When the valve is set at 50% of nominal flow, the curve begins to remain constant at 15 kPa, therefore the working range of the valve is $15 \div 400$ kPa.

The following diagrams show the start-up pressure at different presetting.



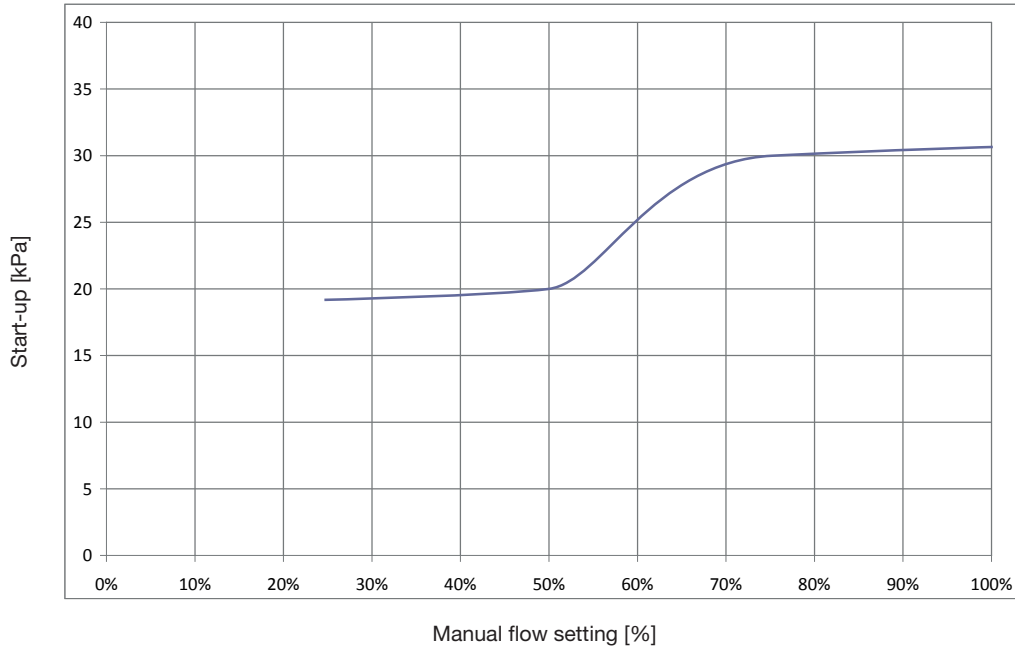

Valve model
83HPR1 1 1/4" - 6000 l/h
83LPR1 1 1/2" - 6000 l/h

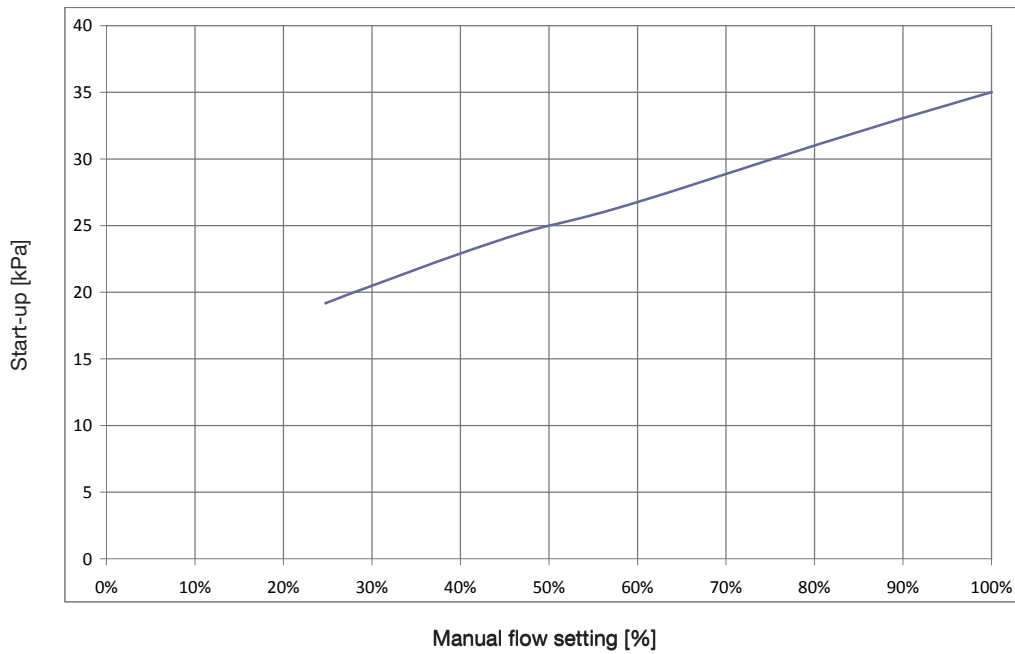

Valve model
83HPR1 1 1/2" - 9000 l/h

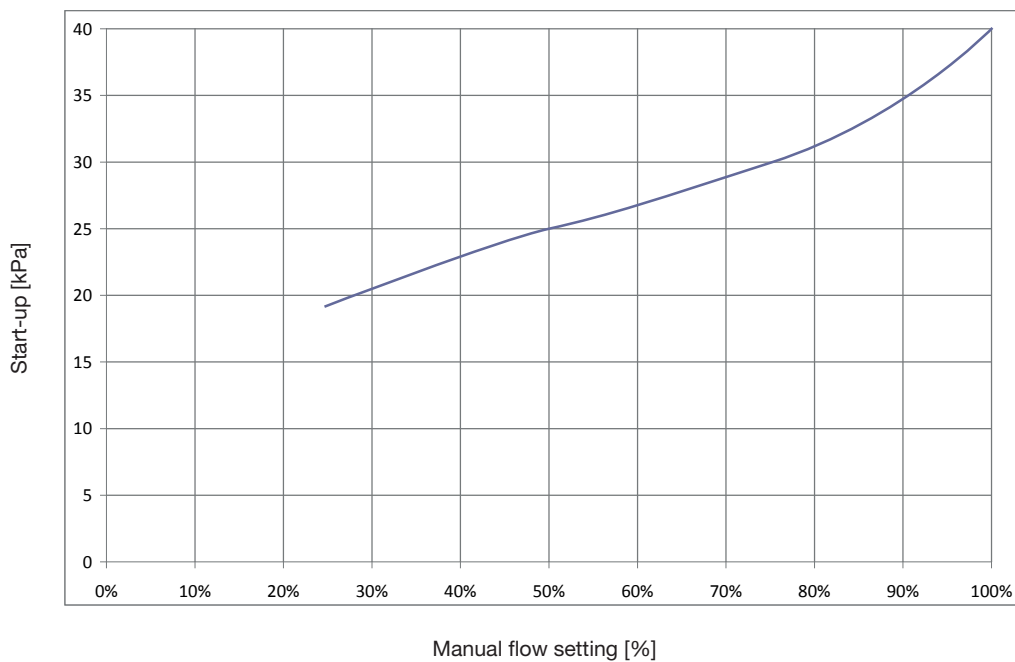

Valve model
83VLPR1 2" - 11000 l/h



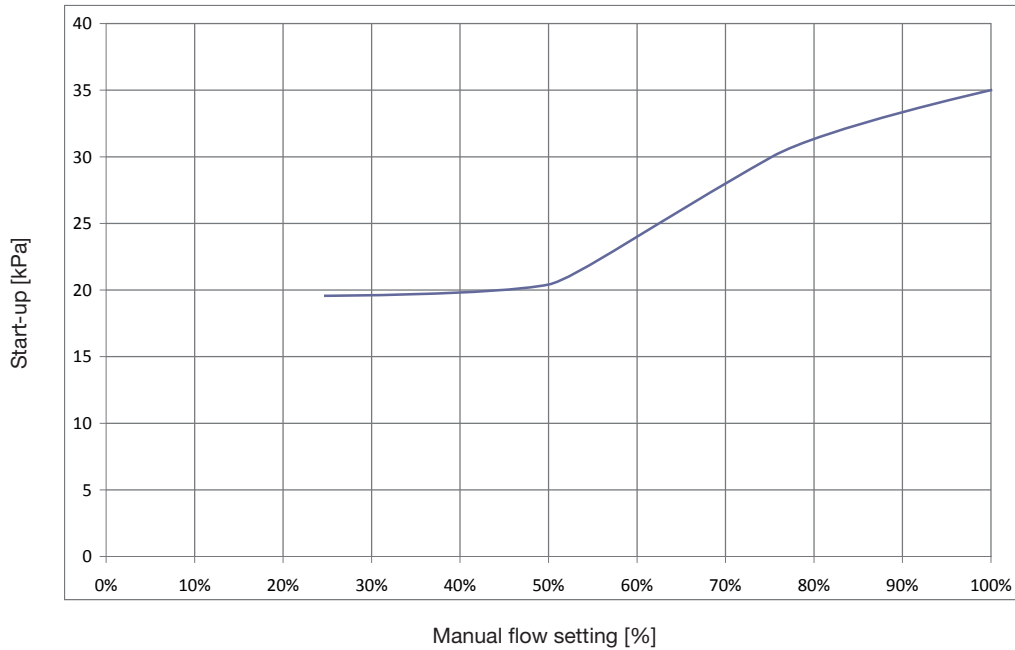

Valve model
83LPR1 2" - 12000 l/h

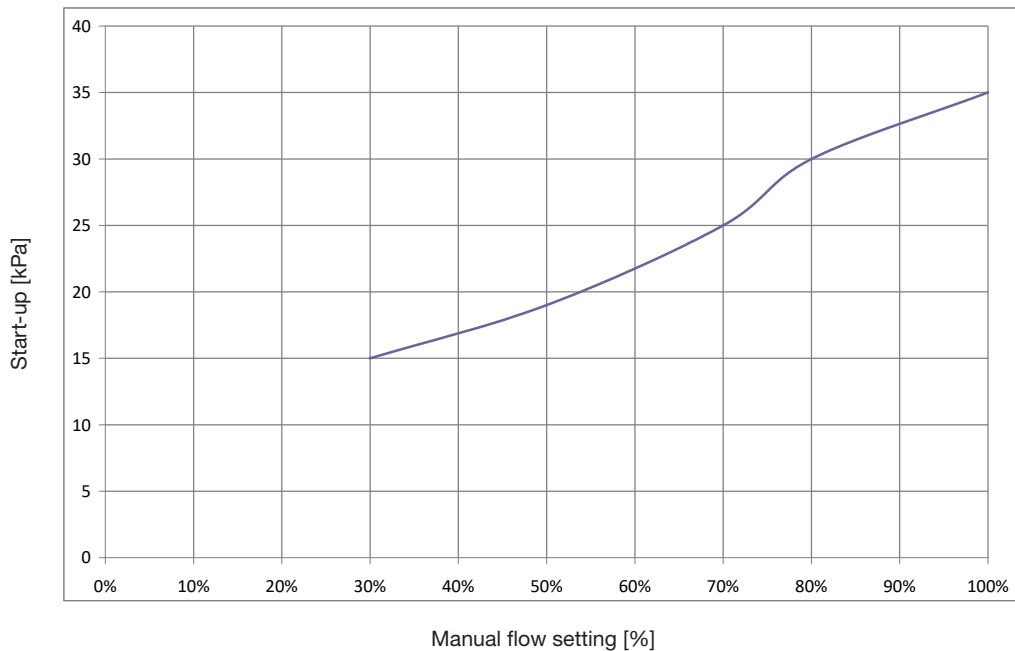

Valve model
83HPR1 2" - 18000 l/h

Flow pre-setting 83 DN40 and DN50 EvoPICV

Presetting %	83HPR1 1 1/4"		83LPR1 1 1/2"		83HPR1 1 1/2"		83VLPR1 2"		83LPR1 2"		83HPR1 2"	
	Flow rate		Flow rate		Flow rate		Flow rate		Flow rate		Flow rate	
	l/h	l/s	l/h	l/s	l/h	l/s	l/h	l/s	l/h	l/s	l/h	l/s
100	6000	1,667	6000	1,667	9000	2,500	11000	3,056	12000	3,333	18000	5,000
90	5400	1,500	5400	1,500	8100	2,250	9900	2,750	10800	3,000	16200	4,500
80	4800	1,333	4800	1,333	7200	2,000	8800	2,444	9600	2,667	14400	4,000
70	4200	1,167	4200	1,167	6300	1,750	7700	2,139	8400	2,333	12600	3,500
60	3600	1,000	3600	1,000	5400	1,500	6600	1,833	7200	2,000	10800	3,000
50	3000	0,833	3000	0,833	4500	1,250	5500	1,528	6000	1,667	9000	2,500
40	2400	0,667	2400	0,667	3600	1,000	4400	1,222	4800	1,333	7200	2,000
30	1800	0,500	1800	0,500	2700	0,750	3300	0,917	3600	1,000	5400	1,500
20	-	-	-	-	-	-	-	-	-	-	-	-
10	-	-	-	-	-	-	-	-	-	-	-	-



EN Control curves

Operating on the position of the regulating valve control stem A will modify the valve Kv, hence the flow rate. The relation between Kv and stroke is shown in the graph below.

Typical control valve characteristic curves.*

$$K_v \% = K_v / K_{vmax}$$

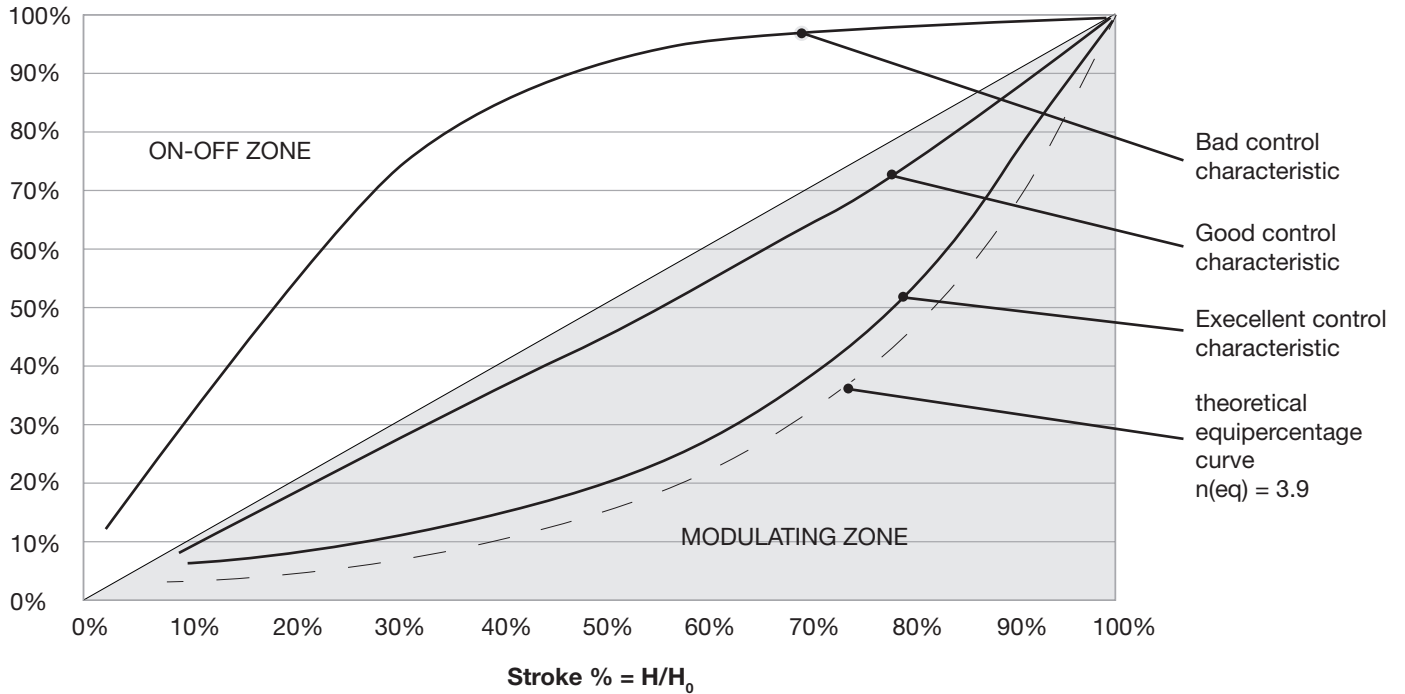

Combining the **EvoPICV** valve characteristic with heat exchanger results in a linear control system.

In the next page control curves of valves 83 DN40 - DN50 are shown.

* Control curve characteristic may change according to valve version.

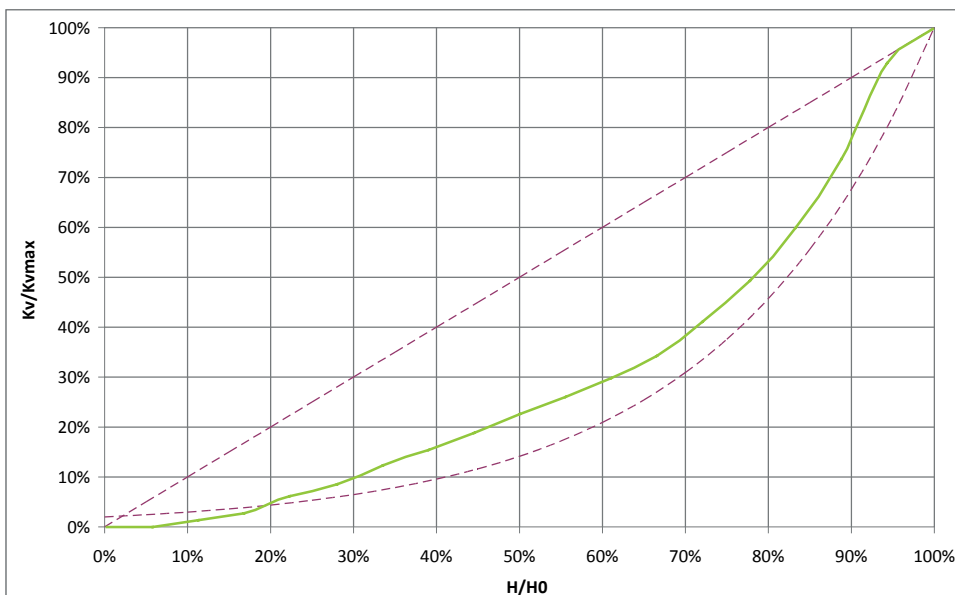

Valve model	
83HPR1	1 1/4" - 6000 l/h
83LPR1	1 1/2" - 6000 l/h
Presetting positions	
—	100% Open

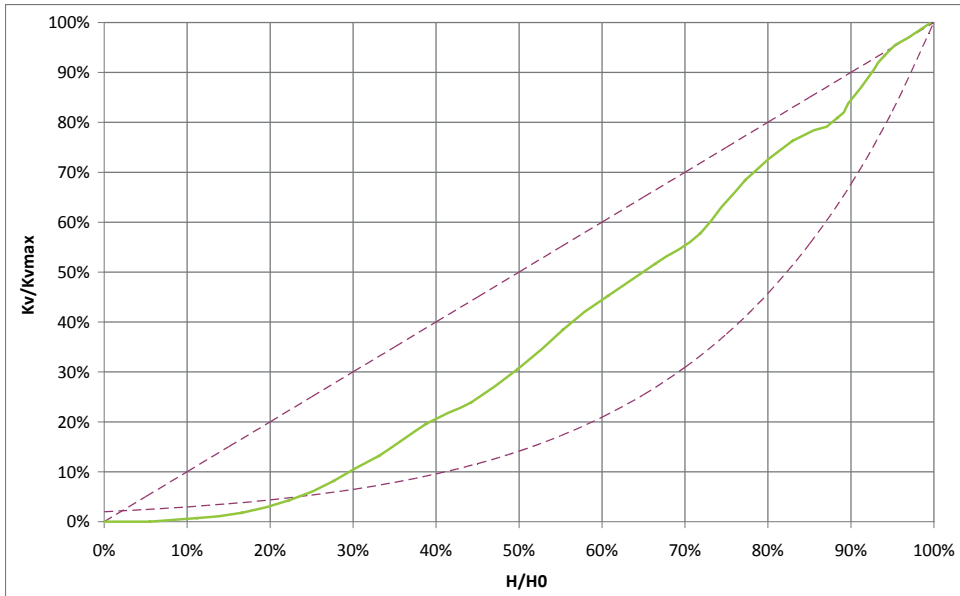

Valve model
83HPR1 1 1/2" - 9000 l/h
Presetting positions
100% Open

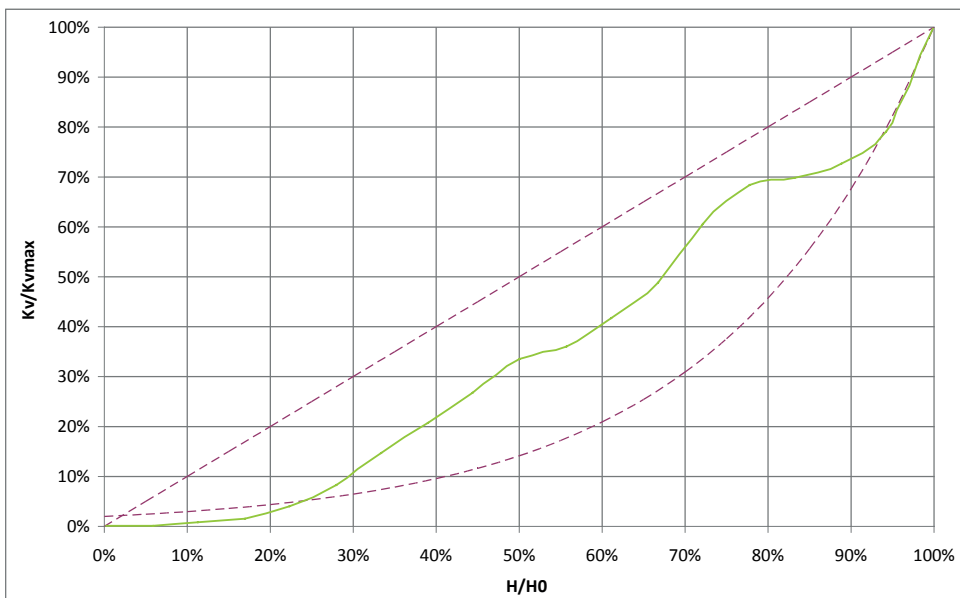

Valve model
83VLPR1 2" - 11000 l/h
Presetting positions
100% Open

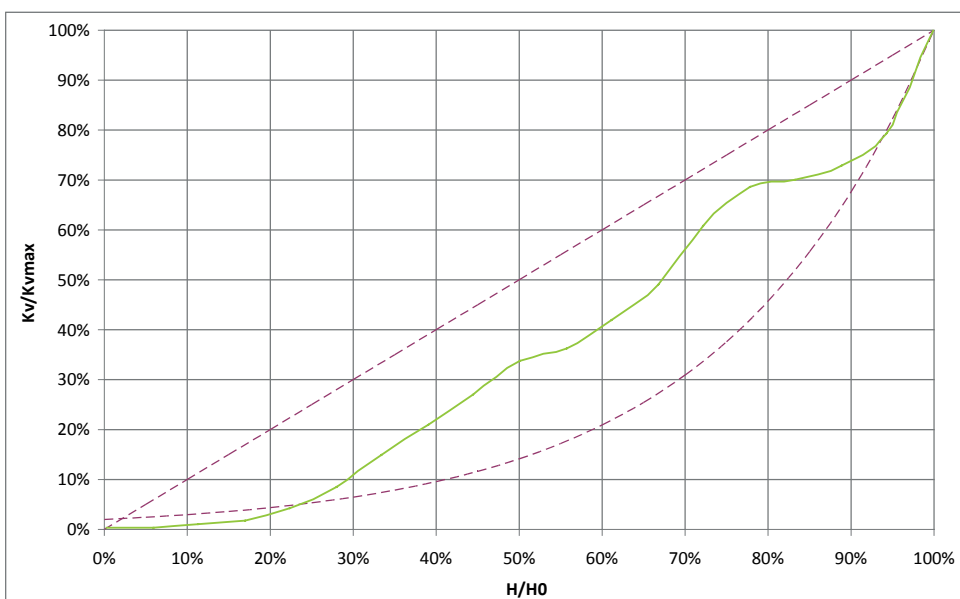

Valve model
83LPR1 2" - 12000 l/h
Presetting positions
100% Open



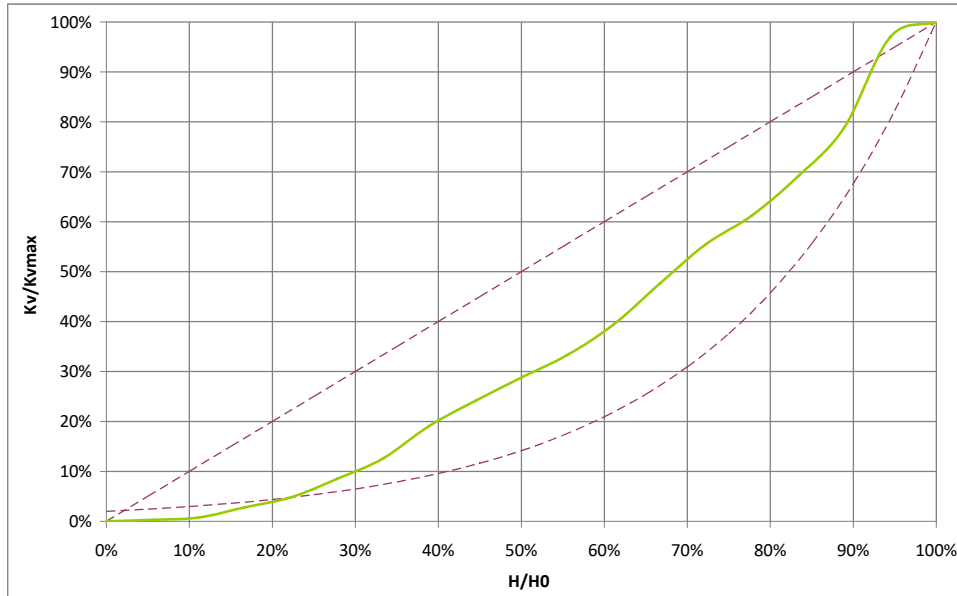

Valve model
 83HPR1 2" - 18000 l/h
 Presetting positions
 — 100% Open

- H: current lift (opening) of the control valve; H varies from 0 to H_0
- H_0 : maximum lift of the control valve;
- K_v : valve flow factor at lift = H
- K_{vmax} : valve flow factor at lift = H_0

EN Actuators

The table below shows actuator part numbers for different control types.

Type	Standard	Stroke
24v or 100-240v, 0-10v Proportional	SN08CC	max. 95°
24v, 3 Point Floating	SN08	max. 95°
230v, 3 Point Floating	SN08	max. 95°
24v, 0-10v Proportional spring return	VA9208C	max. 95°
24v, ON-OFF spring return	VA9208	max. 95°
230v, ON-OFF spring return	VA9208	max. 95°

EN Accessories



MDPS2

Digital differential manometer Bluetooth® for start-up test of PICV valves and flow rate measurement of Terminator balancing valves and Venturi devices. To be used with specific app installed on a smartphone.



MDP

Digital differential manometer differential pressure measurement.



EN Generals

Pettinaroli does not accept any liability for improper or wrong use of this product.

Always protect the pressure regulator by using strainers upstream of the valve and, in any case, make sure water quality complies with UNI 8065 standard. Fratelli Pettinaroli suggests to follow recommendations of VDI 2035/1 too. Maximum suggested content (total) content of Iron and Copper should be: Fe < 0.5 mg/kg and Cu < 0.1 mg/kg.

Furthermore, maximum iron oxide in the water passing through control valve (PICV) must not exceed 25 mg/Kg (25 ppm).

To ensure the main pipework is cleaned appropriately, flushing by-passes should be used without flushing through the pressure regulator of the PICV thereby preventing dirt that might clog the valve.

*The product color may be different with the actual product color due to printing procedure. *The appearance and specifications may change with no prior notice for improvement.

*The data and photo should not be used without permission of the copyright holder.